

FREE LIFT (Figure 11-5) THREE STAGE FULL FREE-LIFT

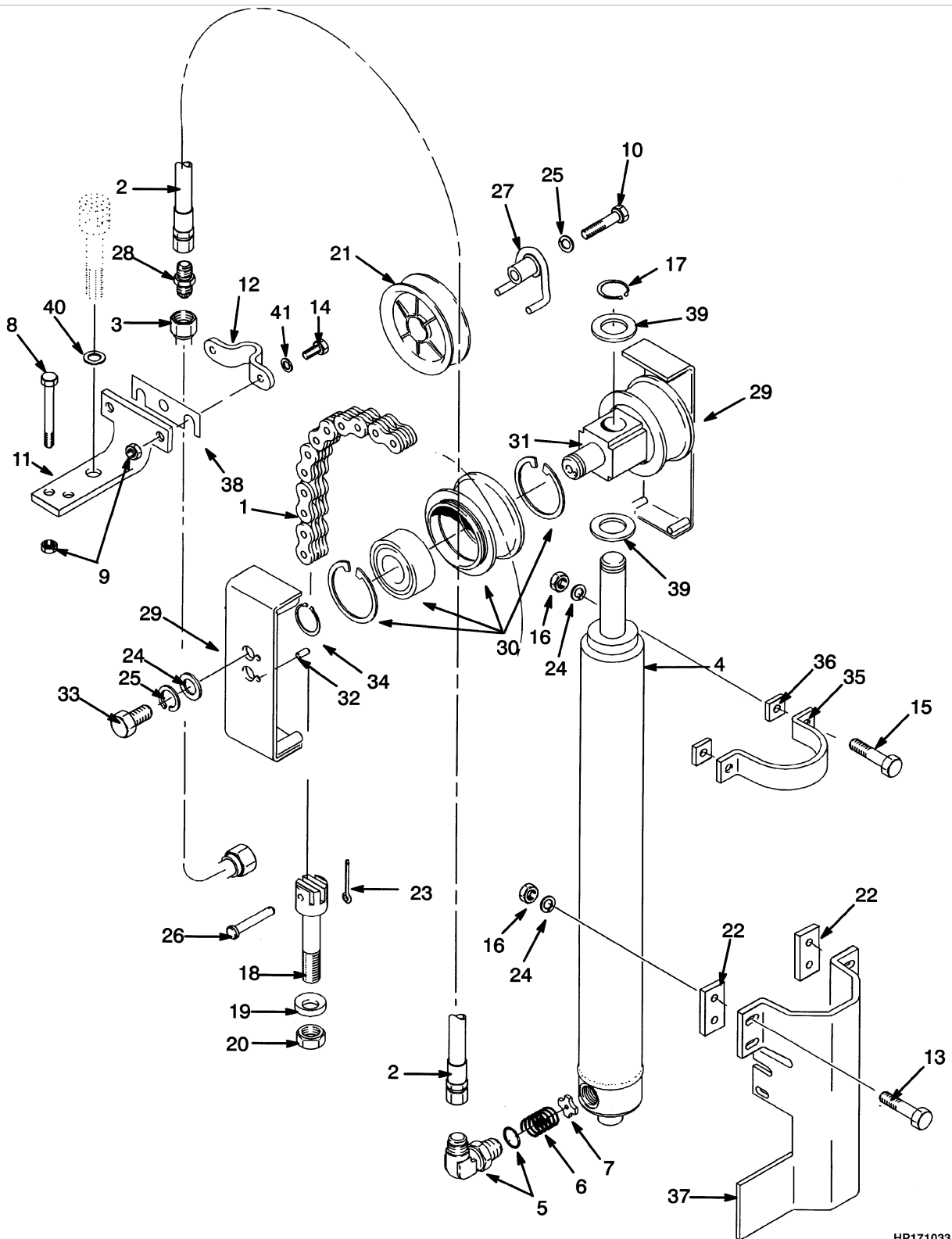

HP171033

**FREE LIFT
THREE STAGE FULL FREE-LIFT**

H45-55XM

ITEM	DESCRIPTION 1 2 3 4	LIFT HEIGHT TO BOTTOM OF FORKS			
		4310 mm (169.7 in.)	4760 mm (187.4 in.)	4910 mm (193.3 in.)	5510 mm (216.9 in.)
		Mast Group Number	B508 4310	B508 4760	B508 4910
1	Chain	197345	180177	161029	180057
2	Hose	1342407	1342410	1342411	1342415
3	Tube	1345359	1345362	1345363	1345362

H60-65XM

ITEM	DESCRIPTION 1 2 3 4	LIFT HEIGHT TO BOTTOM OF FORKS					
		4118 mm (162.1 in.)	4568 mm (179.8 in.)	4718 mm (185.7 in.)	4868 mm (191.7 in.)	5318 mm (209.4 in.)	5918 mm (233.0 in.)
		Mast Group Number	B563 4118	B563 4568	B563 4718	B563 4868	B563 5318
1	Chain	1342391	1369328	1342116	1342118	1342121	1342384
2	Hose	1342407	1342410	1342411	1342412	1342415	1342419
3	Tube	1345359	1345362	1345363	1345364	1345367	1345371

KEY:

A: H45-55XM

B: H60-65XM

ITEM	PART NO.	DESCRIPTION	QTY	
			A	B
1	a	Chain	2	2
2	a	Hose	1	1
3	a	Tube	1	1
4	Free-Lift Cylinder (☞ Figure 11-7)	1	1
5	238637	Fitting	1	1
5	16485	O-Ring (Face Seal)	1	1
6	154355	Spring	1	1
7	356505	Washer	1	1
8	136704	Capscrew	2	2
9	313828	Nut	4	4
10	292532	Capscrew	1	1
11	1362390	Bracket	1	1
12	1345401	Clamp	1	1
13	287837	Capscrew	4	4
14	136681	Capscrew	2	..
14	136749	Capscrew	2
15	292529	Capscrew	2	..
15	292530	Capscrew	2
16	300937	Nut	6	6
17	131358	Snap Ring	1	1
18	1369357	Chain Anchor	2	..

FREE LIFT THREE STAGE FULL FREE-LIFT

ITEM	PART NO.	DESCRIPTION	QTY	
			A	B
18	1369356	Chain Anchor	2
19	296426	Washer (Hardened)	2	2
20	161003	Nut	2	2
21	1343989	Hose Sheave	1	1
21	1354901	Bushing	1	1
22	1354903	Spacer	2	2
23	15211	Cotter Pin.....	2	2
24	320161	Washer	8	8
25	292683	Lockwasher.....	3	3
26	1514866	Pin	2	2
27	1360534	Stubshaft	1	1
28	17635	Fitting.....	1	1
29	1395285	Chain Guard	2	2
30	1379682	Chain Sheave Assembly	2	..
30	1379683	Chain Sheave Assembly	2
30	1378692	Sheave	1	..
30	1378693	Sheave	1
30	37752	Snap Ring	1	1
30	1378699	Bearing.....	1	1
31	1378690	Crosshead	1	1
32	302461	Pin	2	2
33	292527	Capscrew.....	2	..
33	132680	Capscrew.....	..	2
34	304526	Snap Ring.....	2	2
35	1465504	Clamp	1	1
36	1354902	Spacer	2	2
37	1354962	Bracket.....	1	1
38	325616	Spacer	AR	AR
39	b 1362433	Spacer	4	4
40	320165	Washer	1	1
41	320157	Washer	2	2

FOOTNOTES:

- a** Refer to Table
- b** ⇒ S/N B563V-7095

MAIN CYLINDER (Figure 11-6) THREE STAGE FULL FREE-LIFT

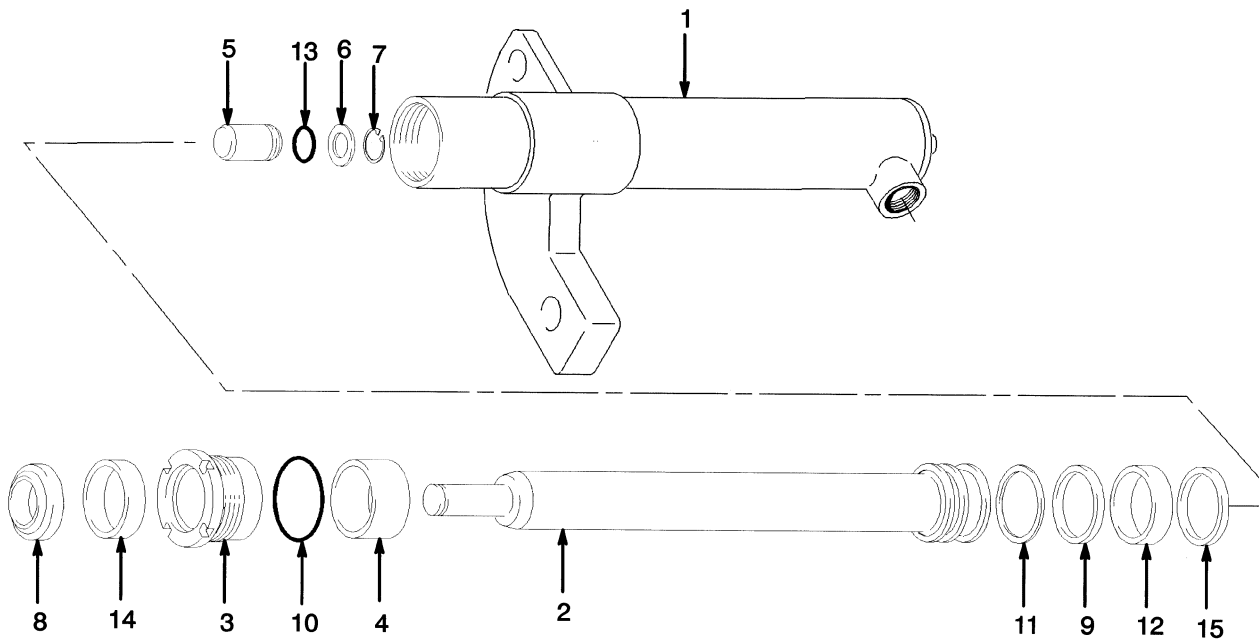

HP171035

**MAIN CYLINDER
THREE STAGE FULL FREE-LIFT****H45-55XM LEFT HAND**

ITEM	DESCRIPTION 1 2 3 4	LIFT HEIGHT TO BOTTOM OF FORKS			
		4310 mm (169.7 in.)	4760 mm (187.4 in.)	4910 mm (193.3 in.)	5510 mm (216.9 in.)
		Mast Group Number	B508 4310	B508 4760	B508 4910
	Cylinder Group Number	8600405	8600408	8600409	8600413
	Lift Cylinder	1341575	1341578	1341579	1341583
1	Shell	1358973	1355598	1355602	1355619
2	Rod	1355587	1355599	1355603	1355620

H45-55XM RIGHT HAND

ITEM	DESCRIPTION 1 2 3 4	LIFT HEIGHT TO BOTTOM OF FORKS			
		4310 mm (169.7 in.)	4760 mm (187.4 in.)	4910 mm (193.3 in.)	5510 mm (216.9 in.)
		Mast Group Number	B508 4310	B508 4760	B508 4910
	Cylinder Group Number	8600455	8600458	8600459	8600463
	Lift Cylinder	1341542	1341545	1341546	1341550
1	Shell	1355589	1355601	1355605	1355622
2	Rod	1355587	1355599	1355603	1355620

H60-65XM LEFT HAND

ITEM	DESCRIPTION 1 2 3 4	LIFT HEIGHT TO BOTTOM OF FORKS					
		4118 mm (162.1 in.)	4568 mm (179.8 in.)	4718 mm (185.7 in.)	4868 mm (191.7 in.)	5318 mm (209.4 in.)	5918 mm (233.0 in.)
		Mast Group Number	B563 4118	B563 4568	B563 4718	B563 4868	B563 5318
	Cylinder Group Number	8600505	8600508	8600509	8600510	8600513	8600517
	Lift Cylinder	1341641	1341644	1341645	1341646	1341649	1341653
1	Shell	1355728	1355740	1355744	1355748	1355757	1355744
2	Rod	1355729	1355741	1355745	1355749	1355758	1355775

MAIN CYLINDER THREE STAGE FULL FREE-LIFT H60-65XM RIGHT HAND

ITEM	DESCRIPTION 1 2 3 4	LIFT HEIGHT TO BOTTOM OF FORKS					
		4118 mm (162.1 in.)	4568 mm (179.8 in.)	4718 mm (185.7 in.)	4868 mm (191.7 in.)	5318 mm (209.4 in.)	5918 mm (233.0 in.)
		Mast Group Number	B563 4118	B563 4568	B563 4718	B563 4868	B563 5318
	Cylinder Group Number	8600555	8600558	8600559	8600560	8600563	8600567
	Lift Cylinder	1341608	1341611	1341612	1341613	1341616	1341620
1	Shell	1355731	1355743	1355747	1355752	1355760	1355777
2	Rod	1355729	1355741	1355745	1355749	1355758	1355775

KEY:

- A: H45-55XM**
- B: H60-65XM**

ITEM	PART NO.	DESCRIPTION	QTY	
			A	B
	d	Lift Cylinder.....	1	1
1	d	Shell	1	1
2	d	Rod.....	1	1
3	1355496	Gland.....	1	..
3	1355713	Gland.....	..	1
4	c 1355610	Spacer	1	..
4	a 1355711	Spacer	1
4	b 1355751	Spacer	1
5	257913	Check Valve.....	1	1
6	297531	Washer	1	1
7	187388	Snap Ring.....	1	1
8	1319668	Wiper Ring.....	1	1
9	2013075	Seal	1	..
9	334156	Seal	1
10	59229	O-Ring	1
10	92861	O-Ring	1	..
11	335012	Back-Up Ring	1
11	638246	Back-Up Ring	1	..
12	1356750	Wear Ring	1	..
12	1356751	Wear Ring	1
13	39348	O-Ring	1	1
14	1381095	Rod Seal.....	1	1
15	1356748	Piston Ring.....	..	1
15	1360127	Piston Ring.....	1	1
	1355497	Seal Kit (Includes Items 8-15)	1	..
	1355714	Seal Kit (Includes Items 8-15)	1

FOOTNOTES:

- a** For Lift Heights 162.1 in. and 179.8 in.
- b** For Lift Heights 191.7 in. and 209.4 in.
- c** For Lift Heights 216.9 in.
- d** Refer to Table

FREE-LIFT CYLINDER (Figure 11-7)
THREE STAGE FULL FREE-LIFT
(⇒S/N B508V-18484 EXC. 18477, ⇒S/N B563V-7094)

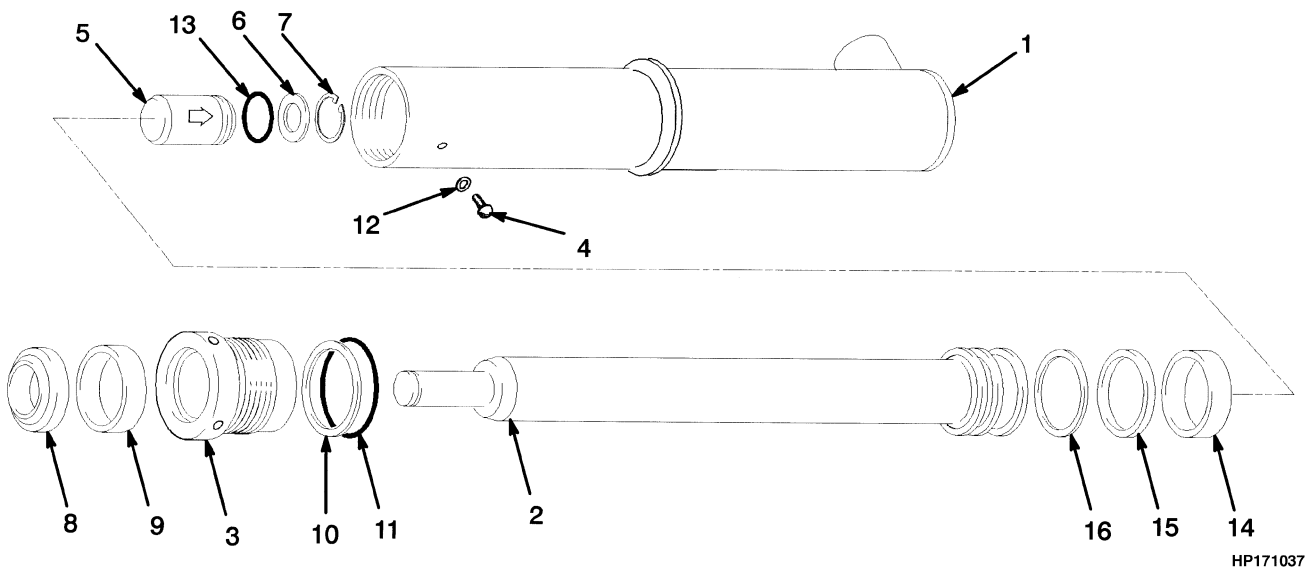

**FREE-LIFT CYLINDER
THREE STAGE FULL FREE-LIFT
(⇒S/N B508V-18484 EXC. 18477, ⇒S/N B563V-7094)**

H45-55XM

ITEM	DESCRIPTION 1 2 3 4	LIFT HEIGHT TO BOTTOM OF FORKS		
		4310 mm (169.7 in.)	4760 mm (187.4 in.)	5510 mm (216.9 in.)
		Mast Group Number	B508 4310	B508 4760
Cylinder Group Number	8603406	8603409	8603415	
	Lift Cylinder	2309480	2303951	2303489
1	Shell	2303871	2311434	2309770
2	Rod	2306774	2311141	2309044

H60-65XM

ITEM	DESCRIPTION 1 2 3 4	LIFT HEIGHT TO BOTTOM OF FORKS			
		4118 mm (162.1 in.)	4568 mm (179.8 in.)	4868 mm (191.7 in.)	5318 mm (209.4 in.)
		Mast Group Number	B563 4118	B563 4568	B563 4868
Cylinder Group Number	8603507	8603510	8603513	8603516	
	Lift Cylinder	2310270	2302410	2303532	2307773
1	Shell	2311691	2305742	2309026	2309353
2	Rod	2303824	2304216	2309410	2303899

KEY:

A: H45-55XM

B: H60-65XM

ITEM	PART NO.	DESCRIPTION	QTY	
			A	B
	a	Lift Cylinder.....	1	1
1	a	Shell	1	1
2	a	Rod.....	1	1
3	1356292	Gland.....	1	..
3	1356661	Gland.....	..	1
4	1361302	Screw	1	1
5	257913	Check Valve.....	1	1
6	297531	Washer	1	1
7	187388	Snap Ring.....	1	1
8	2013099	Wiper	1	1
9	1358970	Seal	1	1
10	147973	Back-Up Ring	1	..
10	164840	Back-Up Ring	1
11	15880	O-Ring.....	..	1
11	90263	O-Ring.....	1	..

FREE-LIFT CYLINDER
THREE STAGE FULL FREE-LIFT
(⇒S/N B508V-18484 EXC. 18477, ⇒S/N B563V-7094)

ITEM	PART NO.	DESCRIPTION	QTY	
			A	B
12	190887	Seal	1	1
13	39348	O-Ring	1	1
14	1358972	Wear Ring	1	..
14	636941	Wear Ring	1
15	2013088	Seal	1	..
15	309062	Seal	1
16	2013089	Back-Up Ring	1	..
16	637565	Back-Up Ring	1
	1356662	Seal Kit (Includes Items 8-16)	1
	1358969	Seal Kit (Includes Items 8-16)	1	..

FOOTNOTES:

a Refer to Table

FREE-LIFT CYLINDER (Figure 11-8)
THREE STAGE FULL FREE-LIFT
(S/N B508V-18585 INC. 18477↔S/N PENDING PER ECN 73703-01, S/N B563V-07095↔S/N PENDING PER ECN 73703-01)

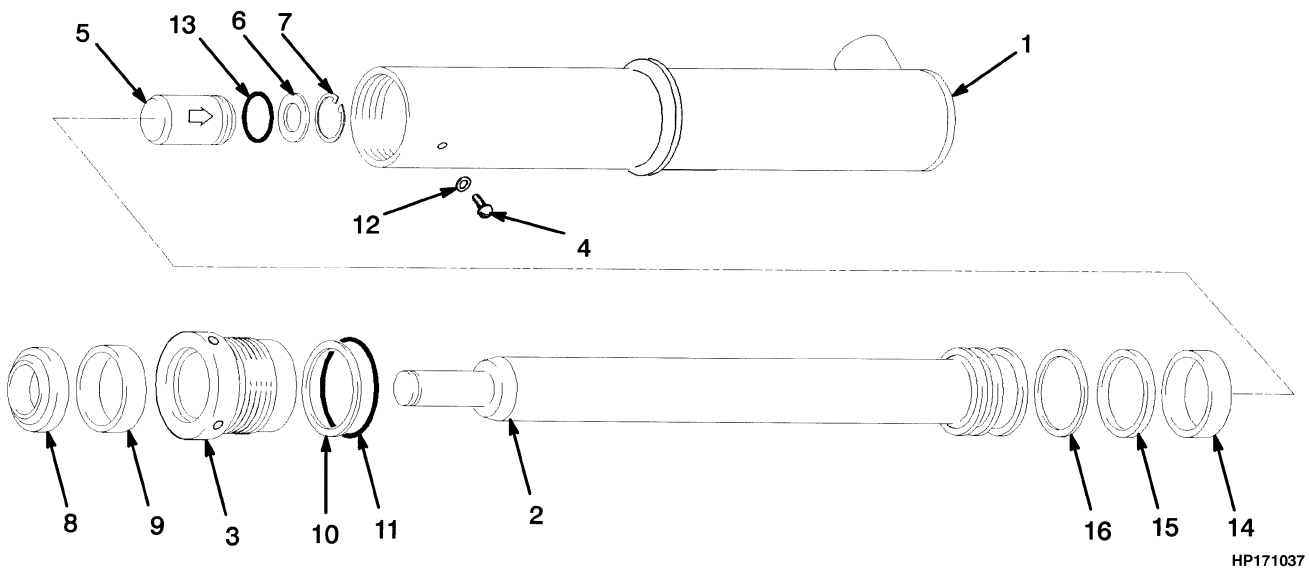

HP171037

**FREE-LIFT CYLINDER
THREE STAGE FULL FREE-LIFT
(S/N B508V-18585 INC. 18477↔S/N PENDING PER ECN 73703-01, S/N B563V-07095↔S/N PENDING PER ECN 73703-01)**

H45-55XM

ITEM	DESCRIPTION 1 2 3 4	LIFT HEIGHT TO BOTTOM OF FORKS			
		4310 mm (169.7 in.)	4760 mm (187.4 in.)	4910 mm (193.3 in.)	5510 mm (216.9 in.)
		Mast Group Number	Mast Group Number	Mast Group Number	Mast Group Number
	Cylinder Group Number	8602406	8602409	8602410	8602415
	Lift Cylinder	1366733	1366736	1366737	1366742
1	Shell	2303871	2311434	2310340	2309770
2	Rod	1356560	1356569	1356572	1371631

H60-65XM

ITEM	DESCRIPTION 1 2 3 4	LIFT HEIGHT TO BOTTOM OF FORKS			
		4118 mm (162.1 in.)	4568 mm (179.8 in.)	4868 mm (191.7 in.)	5318 mm (209.4 in.)
		Mast Group Number	Mast Group Number	Mast Group Number	Mast Group Number
	Cylinder Group Number	8602507	8602510	8602513	8602516
	Lift Cylinder	1369549	1371602	1371605	1371608
1	Shell	2311691	2305742	2309026	2309353
2	Rod	1356682	1356691	1356065	1356074

KEY:

A: H45-55XM

B: H60-65XM

ITEM	PART NO.	DESCRIPTION	QTY	
			A	B
	a	Lift Cylinder.....	1	1
1	a	Shell	1	1
2	a	Rod.....	1	1
3	1356292	Gland.....	1	..
3	1356661	Gland.....	..	1
4	1361302	Screw	1	1
5	257913	Check Valve.....	1	1
6	297531	Washer	1	1
7	187388	Snap Ring.....	1	1
8	2013099	Wiper	1	1
9	1358970	Seal	1	1
10	147973	Back-Up Ring	1	..
10	164840	Back-Up Ring	1
11	15880	O-Ring.....	..	1

**FREE-LIFT CYLINDER
THREE STAGE FULL FREE-LIFT
(S/N B508V-18585 INC. 18477↔S/N PENDING PER ECN 73703-01, S/N B563V-
07095↔S/N PENDING PER ECN 73703-01)**

ITEM	PART NO.	DESCRIPTION	QTY	
			A	B
11	90263	O-Ring	1	..
12	190887	Seal	1	1
13	39348	O-Ring	1	1
14	1358972	Wear Ring	1	..
14	636941	Wear Ring	1
15	2013088	Seal	1	..
15	309062	Seal	1
16	2013089	Back-Up Ring	1	..
16	637565	Back-Up Ring	1
	1356662	Seal Kit (Includes Items 8-9, 11-16)	1	1
	1358969	Seal Kit (Includes Items 8-16)	1	1

FOOTNOTES:

a Refer to Table

FREE-LIFT CYLINDER (Figure 11-9) THREE STAGE FULL FREE LIFT (S/N PENDING PER ECN 73703-01⇒)

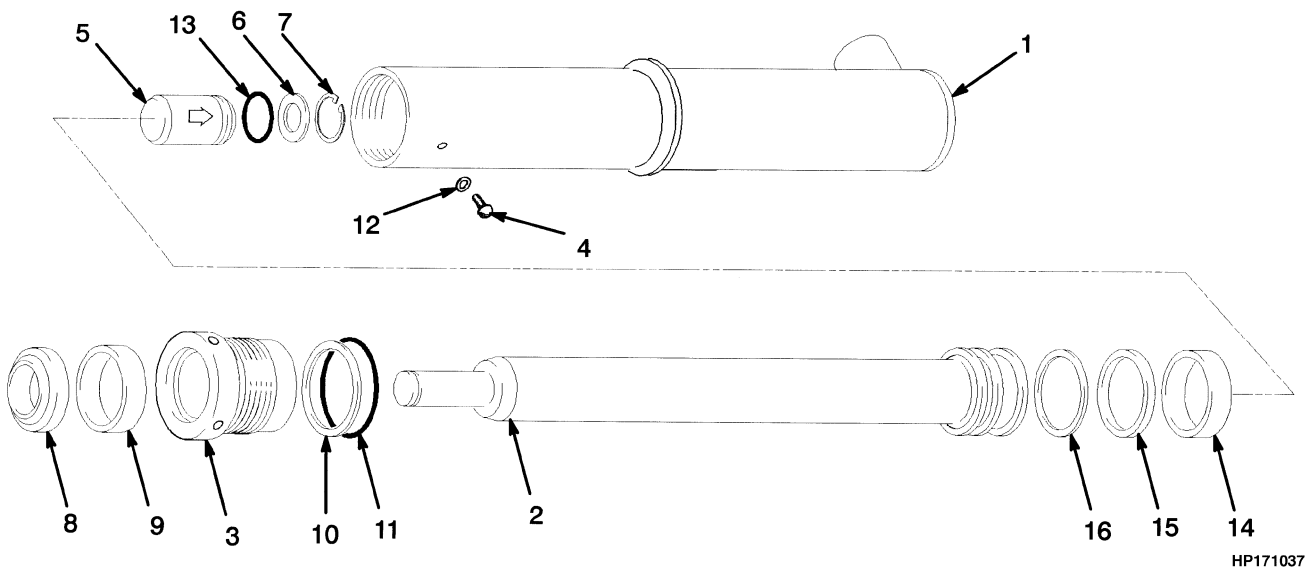

HP171037

**FREE-LIFT CYLINDER
THREE STAGE FULL FREE LIFT
(S/N PENDING PER ECN 73703-01⇒)**

H45-55XM

ITEM	DESCRIPTION 1 2 3 4	LIFT HEIGHT TO BOTTOM OF FORKS			
		4310 mm (169.7 in.)	4760 mm (187.4 in.)	4910 mm (193.3 in.)	5510 mm (216.9 in.)
		Mast Group Number	B508 4310	B508 4760	B508 4910
	Cylinder Group Number	8514556	8514559	8514560	8514565
	Lift Cylinder	2053795	2053796	2053797	2053799
1	Shell	2058210	2058213	2058214	2058219
2	Rod	1356560	1356569	1356572	1356587

H60-65XM

ITEM	DESCRIPTION 1 2 3 4	LIFT HEIGHT TO BOTTOM OF FORKS					
		4118 mm (162.1 in.)	4568 mm (179.8 in.)	4718 mm (185.7 in.)	4868 mm (191.7 in.)	5318 mm (209.4 in.)	5918 mm (233.0 in.)
		Mast Group Number	B563 4118	B563 4568	B563 4718	B563 4868	B563 5318
	Cylinder Group Number	8514507	8514510	8514511	8514513	8514516	8514521
	Lift Cylinder	2053770	2053771	2053772	2053773	2053775	2061875
1	Shell	2063690	2063691	2063645	2064046	2063693	2058259
2	Rod	1356682	1356691	1356694	1356065	1356074	1356089

KEY:

A: H45-55XM

B: H60-65XM

ITEM	PART NO.	DESCRIPTION	QTY	
			A	B
	a	Lift Cylinder.....	1	1
1	a	Shell	1	1
2	a	Rod.....	1	1
3	1356292	Gland.....	1	..
3	1356661	Gland.....	..	1
4	1361302	Screw	1	1
5	257913	Check Valve.....	1	1
6	297531	Washer	1	1
7	187388	Snap Ring.....	1	1
8	2013099	Wiper	1	1
9	1358970	Seal	1	1
10	147973	Back-Up Ring	1	..
10	164840	Back-Up Ring	1
11	90263	O-Ring.....	1	..
11	15880	O-Ring.....	..	1

FREE-LIFT CYLINDER THREE STAGE FULL FREE LIFT (S/N PENDING PER ECN 73703-01⇒)

ITEM	PART NO.	DESCRIPTION	QTY	
			A	B
12	190887	Seal	1	1
13	39348	O-Ring	1	1
14	1358972	Wear Ring	1	..
14	636941	Wear Ring	1
15	2013088	Seal	1	..
15	309062	Seal	1
16	2013089	Back-Up Ring	1	..
16	637565	Back-Up Ring	1
	1358969	Seal Kit (Includes Items 8-16)	1	..
	1356662	Seal Kit (Includes Items 8-16)	1

FOOTNOTES:

a Refer to Table

CARRIAGE (Figure 11-10) THREE STAGE FULL FREE-LIFT SIX ROLLER

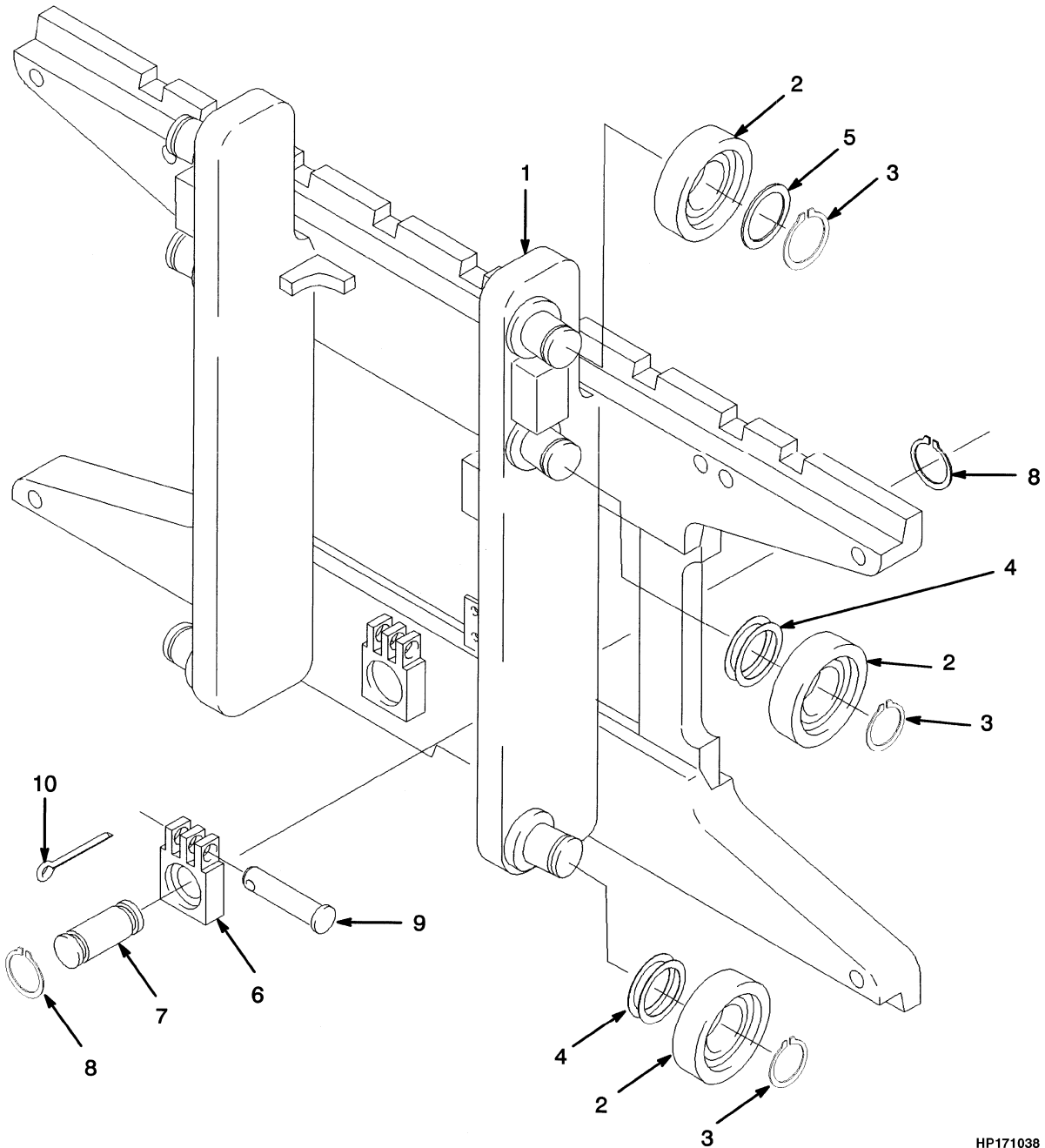

HP171038

CARRIAGE THREE STAGE FULL FREE-LIFT SIX ROLLER

KEY:**A: H45-55XM****B: H60-65XM**

ITEM	PART NO.	DESCRIPTION	QTY	
			A	B
	1379459	Carriage Assembly (42 in.) (Group No. 8500275).....	1	..
	1379460	Carriage Assembly (42 in.) (Group No. 8500276).....	..	1
	1379463	Carriage Assembly (48 in.) (Group No. 8500279).....	1	..
1	1381560	Frame (42 in.).....	1	..
1	1381561	Frame (42 in.).....	..	1
1	1381564	Frame (48 in.).....	1	..
1	1345216	Stubshaft.....	6	6
2	1333399	Load Roller (Standard).....	6	6
2	1337900	Load Roller (1,52 mm).....	6	6
3	58901	Snap Ring.....	6	6
4	129387	Shim (0.020 in.).....	AR	AR
5	366115	Spacer.....	2	2
6	1369344	Chain Anchor (Dual Hole).....	..	2
6	1504012	Chain Anchor (Single Hole) (Optional).....	..	2
6	1369345	Chain Anchor (Dual Hole).....	2	..
6	1504010	Chain Anchor (Single Hole) (Optional).....	2	..
7	317735	Pin.....	2	2
8	131358	Snap Ring.....	4	4
9	1514866	Pin.....	2	2
10	15211	Cotter Pin.....	2	2

HEADER HOSE (Figure 11-11) THREE STAGE FULL FREE-LIFT

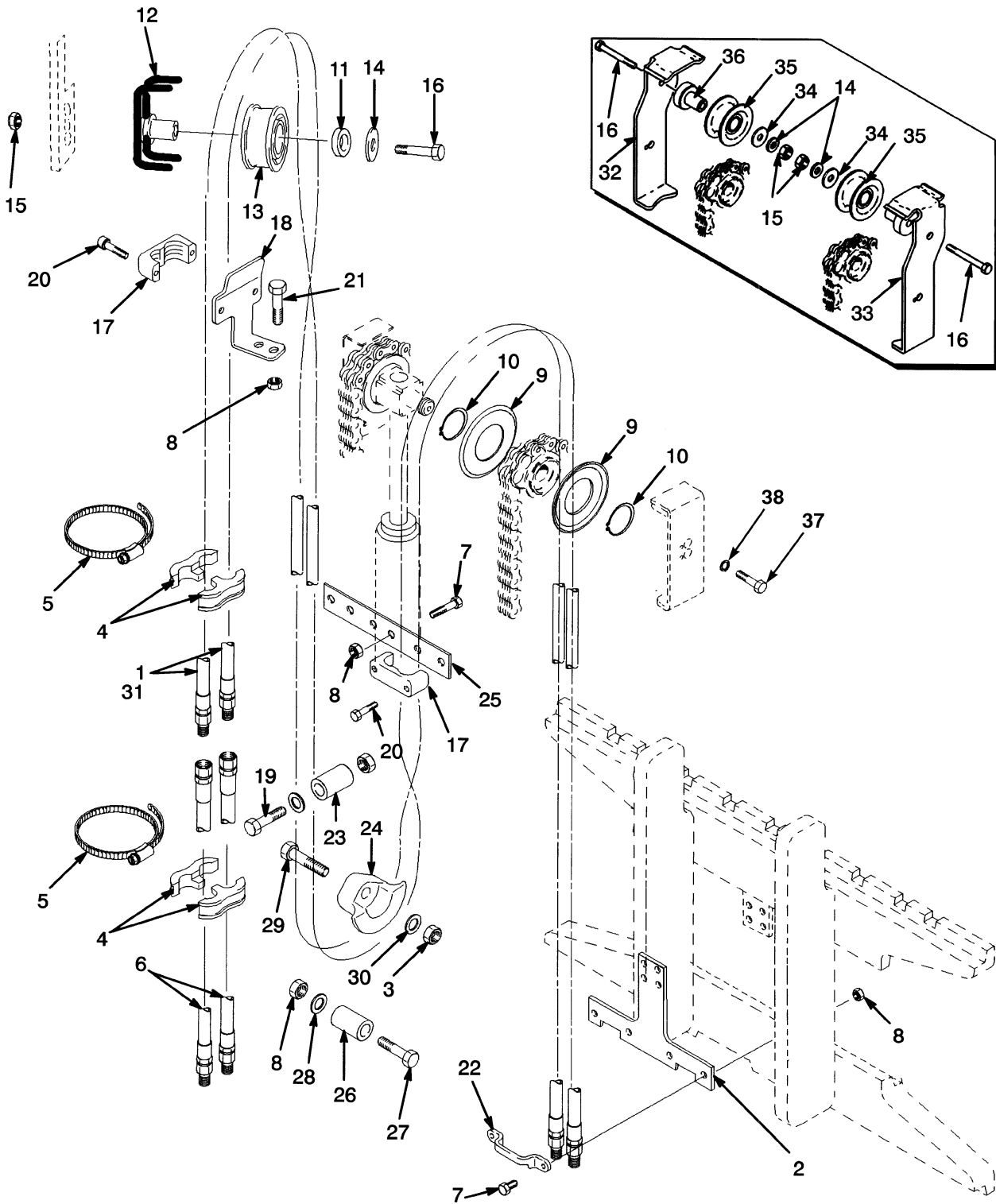

HP171041

**HEADER HOSE
THREE STAGE FULL FREE-LIFT****H45-55XM**

ITEM	DESCRIPTION 1 2 3 4	LIFT HEIGHT TO BOTTOM OF FORKS			
		4310 mm (169.7 in.)	4760 mm (187.4 in.)	4910 mm (193.3 in.)	5510 mm (216.9 in.)
		Mast Group Number	B508 4310	B508 4760	B508 4910
1	Hose	b 1358352 c 1368411	b 1369625 c 1376131	b 1358354 c 1368414	b 1369627 c 1358360
31	Hose	1368445	1398951	1376133	1398595

H60-65XM

ITEM	DESCRIPTION 1 2 3 4	LIFT HEIGHT TO BOTTOM OF FORKS					
		4118 mm (162.1 in.)	4568 mm (179.8 in.)	4718 mm (185.7 in.)	4868 mm (191.7 in.)	5318 mm (209.4 in.)	5918 mm (233.0 in.)
		Mast Group Number	B563 4118	B563 4568	B563 4718	B563 4868	B563 5318
1	Hose	d 1358352 e 1368411	d 1369625 e 1376131	b 1358354 e 1368414	d 1358355 e 1376161	d 1369627 e 1376164	d 1351792 e 1376167
31	Hose	1368445	1398951	1376133	1369643	1398595	1398604

KEY:**A: Three Function****B: Four Function**

ITEM	PART NO.	DESCRIPTION	QTY	
			A	B
1	a	Hose	2	2
2	1381771	Bracket (H45-55XM)	1	1
2	1381772	Bracket (H60-65XM)	1	1
3	316826	Nut	1	2
4	1353530	Clamp	4	8
5	1360507	Clamp	2	4
6	1354904	Hose (LH)	2
6	1354922	Hose (RH)	2	2
7	136749	Capscrew	8	10
8	313828	Nut	9	14
9	1345199	Hose Guide	2	4
10	1345204	Snap Ring	2	4
11	1360549	Spacer	1	2
12	1362387	Stubshaft	1	2
13	1494017	Sheave	1	2
14	1345190	Washer	1	2
15	1390182	Nut	1	2
16	292533	Capscrew	1	2
17	1360386	Clamp	2	4
18	1354906	Bracket (RH)	1	1
18	1354907	Bracket (LH)	1
19	292534	Capscrew	1	2

HEADER HOSE THREE STAGE FULL FREE-LIFT

ITEM	PART NO.	DESCRIPTION	QTY	
			A	B
20	293795	Capscrew	4	8
21	136704	Capscrew	2	4
22	1369333	Clamp	1	2
23	1360538	Tube	1	2
24	1348246	Hose Guide (RH)	1	1
24	1348247	Hose Guide (LH).....	..	1
25	1353464	Plate	1	1
26	1354961	Restraint	1	2
27	214364	Capscrew	1	2
28	320158	Washer	1	2
29	287860	Capscrew	1	2
30	320160	Washer	1	2
31	a	Hose	2
32	ce 1395291	Bracket (RH) (RH)	1	1
33	ce 1395292	Bracket (LH) (LH).....	..	1
34	ce 1396407	Spacer	1	2
35	ce 1345194	Sheave.....	1	2
36	ce 1396406	Stubshaft	1	2
37	292527	Capscrew	2	2
38	320161	Washer	2	2

FOOTNOTES:

- a** Refer to Table
- b** ⇒ S/N B508V-24129
- c** S/N B508V-24130 ⇒
- d** ⇒ S/N B563V-9115
- e** S/N B563V-9116 ⇒